



GH3/GH3+ Lifting modules Technical specifications

Weight and materials

SWL	: 200 kg, 250 kg, 275 kg
Own weight	: 9,6 kg
with horizontal motor	: 10,5 kg
with scale module and horizontal motor	: 11,1 kg

SWL	: 300 kg, 350 kg, 375 kg, 400 kg
Own weight	: 14,2 kg
with horizontal motor	: 15,9 kg
with scale module and horizontal motor	: 17,3 kg

Covers : Impact-resistant UL 94 V-0 flame retardant recyclable plastic

Dimensions

A	: 580 mm
B	: 345 mm
C	: 156 mm
D	: 184 mm
E, min	: 425 mm
F	: 2.500 mm
Depth of hoist	: 205 mm

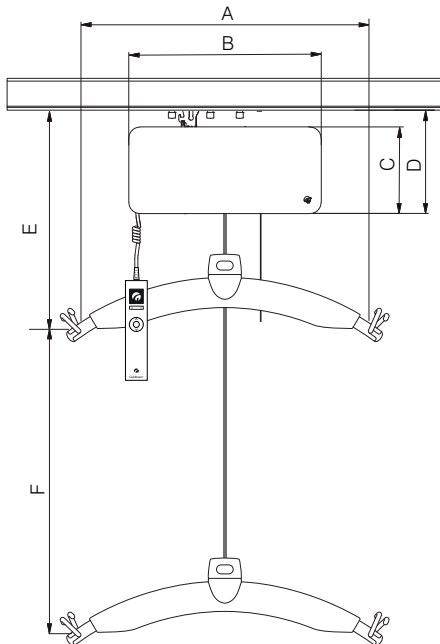

Functions

Operation	: Hand control / IR
Sound level	: 52 dB (A)
Horizontal speed	: 220 mm/sec. (Horizontal drive motor)

Safety

Emergency stop	: Yes
Emergency lowering device	: Yes, mechanical and electrical
Control of lifting strap	: Yes
Cut-off angle	: 45° along the rail 10° across the rail

Electronics

On/off : Automatic when used. Soft start/stop. Overload protection.

SWL	: 200 kg, 250 kg, 275 kg
Battery	: 1 x 24 V NiMH, 2.1 Ah
Max charge time	: 2 hours

SWL	: 300 kg, 350 kg, 375 kg, 400 kg
Battery	: 2 x 24 V NiMH, 2.1 Ah
Max charge time	: 4 hours

Battery protection : At battery voltage below 22 V the indicator light turns orange. The hoist stops if the voltage falls below 20 V

Power supply	: 33 V AC, 2.5 A
Supply voltage, transformer Class I	: 100-240V AC
transformer Class II	: 100-115V AC / 220-230V AC

Protection classification (IP) according to IEC 60529

Lifting module	: IP 20
Hand control	: IP 44
Remote control	: IP 20
Transformer Class I	: IP 20
Transformer Class II	: IP 21

Labelling

The product is manufactured in compliance with regulation (EU) 2017/745 of the European parliament and of the Council of 5 April 2017, as medical device Class I.

Classification

Pursuant to ISO 9999

Patents	: PA 2008 00888 PA 2008 00894 PA 2008 00895
---------	---

Time to care



GH3/GH3+ Lifting modules Technical specifications

GH Lifting modules, configurations						Options											
Guldmann hoist type	Product line	Load in kg	Number of lifting straps	Number of lifting motors	Number of horizontal drive motors x)	IR remote xx)	Service module	CLM module	Scale module	WiFi module	Class III scale	Trainer module	Coating	Excl. Turbospeed	UL	Charg. HC xx)	
GH3	(x)	xxx	x	x	x	Configuration code (xxxxx)											
GH3		200	1	1	0 - 1 - 2	•							•	•	•	•	
		250	1	1	0 - 1 - 2	•							•	•	•	•	
		+	200	1	1	0 - 1 - 2	•	•	•	•	•	•	•	•	•	•	•
		250	1	1	0 - 1 - 2	•	•	•	•	•	•	•	•	•	•	•	•
		275	1	1	0 - 1 - 2	•	•	•	•	•	•	•	•	•	•	•	•
		300	1	2	0 - 2	•	•	•	•	•	•	•	•	•	•	•	•
		350	1	2	0 - 2	•	•	•	•	•	•	•	•	•	•	•	•
		375	1	2	0 - 2	•	•	•	•	•	•	•	•	•	•	•	•
		400	1	2	0	•	•	•	•	•	•	•	•	•	•	•	•

x) Drive motors are not compatible with UL
 xx) Not compatible with UL

Example: GH3+ 350 122 (xxxxx)

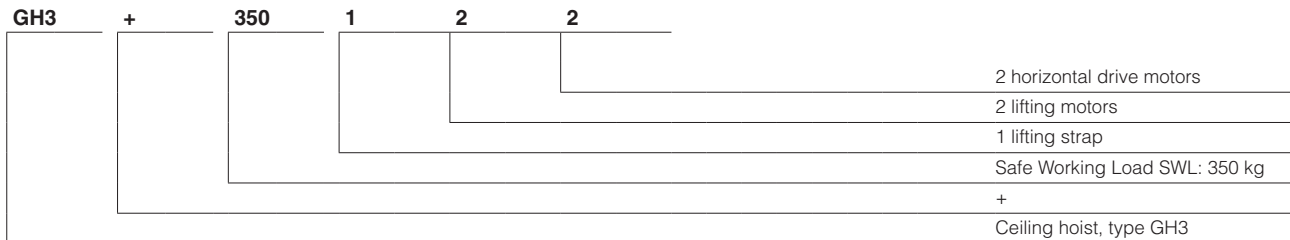

Lifting speed	GH3	GH3+
85 kg load	40 mm/sec.	60 mm/sec.
150 kg load	40 mm/sec.	60 mm/sec.
Max capacity load, SWL	40 mm/sec.	55 mm/sec.
Max 5 kg load	40/100 mm/sec.	60/100 mm/sec.

Number of lift and Intermittent

Max. number of lifts in series : 55 with 85 kg/1000 mm
 Charging time : 2 Hours
 Intermittent : 4 min. ON/16 min. OFF

SWL : 300 kg, 350 kg, 375 kg, 400 kg
 Max. number of lifts in series : 40/1000 mm
 Charging time : 4 Hours
 Intermittent : 2 min. ON/18 min. OFF

SWL : 200 kg, 250 kg, 275 kg
 Max. number of lifts in series : 21/1000 mm
 Charging time : 2 Hours
 Intermittent : 2 min. ON/18 min. OFF